

EN



QUANTRON



BEV | FCEV

Q-Heavy

QUANTRON QHM || QUANTRON QHB

Empower the Future



Quantron AG

Koblenzer Straße 2

D-86368 Gersthofen/Augsburg

Phone: +49 (0) 821 - 78 98 40 - 0

Fax: +49 (0) 821 - 78 98 40 - 99

Mail: info@quantron.net

Web: www.quantron.net



Dear customers,

Quantron AG offers you innovative and practical e-mobility solutions and thus makes a sustainable contribution to the decarbonization of road transport. In the Q-Retrofit business unit, we supply you with environmentally friendly transportation solutions as a new vehicle or as a conversion of an existing diesel vehicle to electric drive. You have the choice! With our Q-Ecosystem, we also offer you an all-round service package - from consulting on a vehicle tailored to your personal needs to the installation of the appropriate charging infrastructure.

Contact us, we will accompany you on your way to e-mobility.

Best regards

A handwritten signature in blue ink, appearing to read 'Andreas Haller'.

Yours, Andreas Haller
Founder and Chairman of the Board of Quantron AG

**QUANTRON
ENERGY**

**QUANTRON
INSIDE**

**QUANTRON
POWER STATION**

**QUANTRON
CUSTOMER CARE**

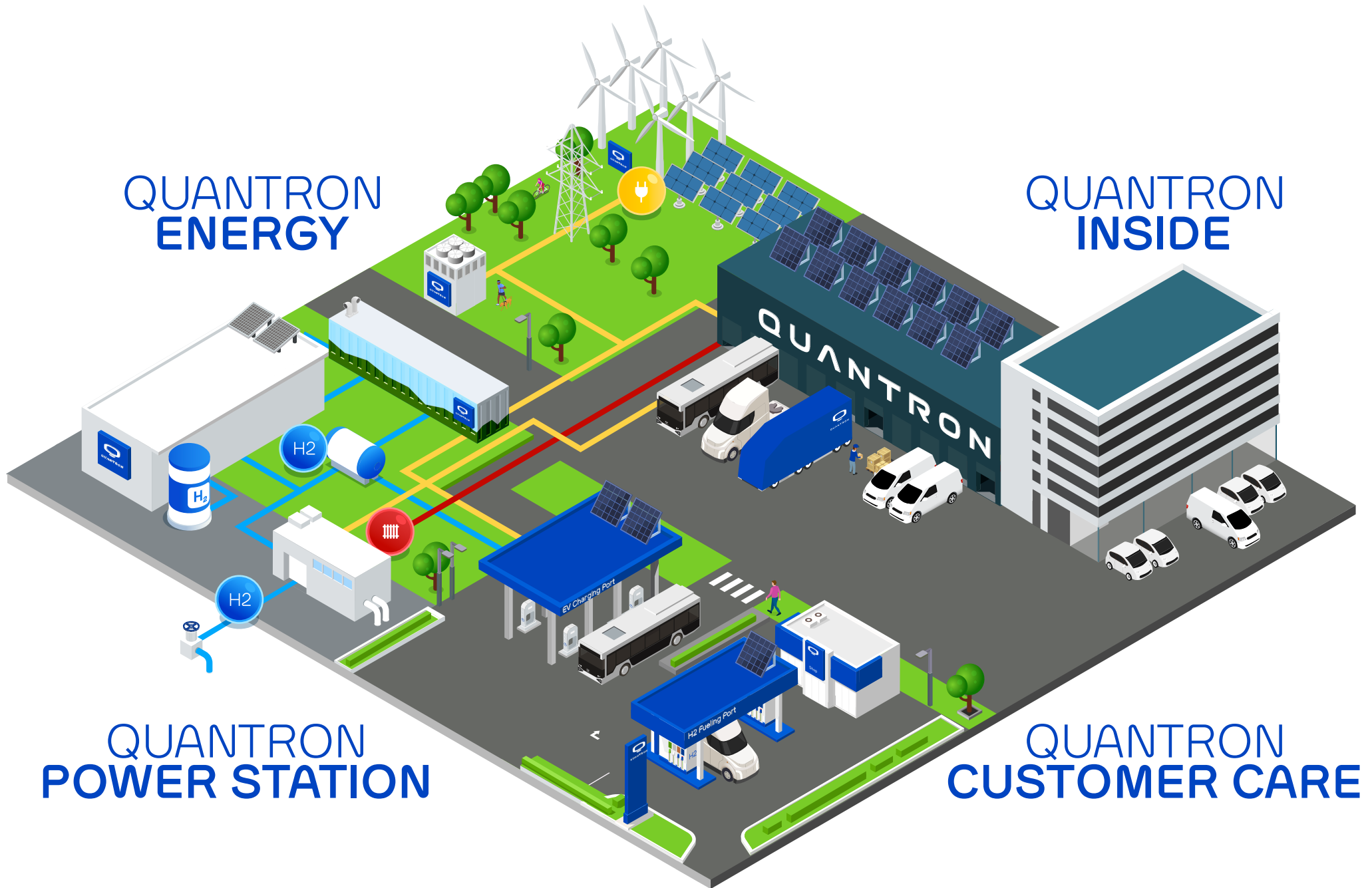

QUANTRON 360° Platform Solution – Quantron-as-a-Service

With QUANTRON-as-a-Service we are aiming for a 360° Zero Emission product & solution ecosystem. This means: QUANTRON is a solution provider offering an “asset-light” solution that encompasses all facets of the mobility value chain, such as the e-vehicle, service & maintenance, insurance, leasing, financing, infrastructure as well as green electricity and hydrogen.

The result: providing comprehensive zero-emission transport solutions on a per-kilometre basis.

This Q-Ecosystem consists of four central areas: QUANTRON ENERGY, QUANTRON INSIDE, QUANTRON CUSTOMER CARE and QUANTRON POWER STATION.

QUANTRON ENERGY

As a central player in a rapidly developing ecosystem, QUANTRON coordinates resources and partners to realise the production of green energy / green hydrogen and the associated supply to customers at competitive prices in the future as a platform.

QUANTRON INSIDE

QUANTRON already supplies working, practical e-commercial vehicles with battery and hydrogen-electric drives based on the highly innovative QUANTRON INSIDE technology. The wide range of products includes new vehicles as well as the resource-saving electrification of used and existing vehicles with diesel engines (Q-retrofit).

QUANTRON POWER STATION

In this area, we cover the topics of charging and hydrogen refuelling. Together with our partners, we are able to offer turnkey solutions for the development of the necessary green charging/fuelling infrastructure for BEVs and FCEVs (own and in cooperation), both at customer depots and along motorways.

QUANTRON CUSTOMER CARE

We offer comprehensive consulting services for the operation of your climate-neutral fleet. This includes, for example, topics such as the appropriate charging infrastructure, rental, financing and leasing options, as well as an all-encompassing aftersales service network with 700 locations. In addition, there are telematics and in-cloud solutions for remote diagnosis and fleet management.

An aerial photograph of a winding asphalt road that curves through a dense, lush green forest. The road has white lane markings and a concrete curb on one side. The perspective is from directly above, showing the road's path as it snakes through the trees.

Have you heard
about the new normal?

Zero Emission. Full Power. Better Future.



 **QUANTRON**



QUANTRON Q-HEAVY

QUANTRON's vision is a greener world. With zero-emission commercial vehicles, we are making our contribution to reducing CO2 emissions and thus to achieving global climate targets. We want to change the future in a sustainable way.

QUANTRON combines over 140 years of commercial vehicle experience as a high-tech spinoff of the family-owned company Haller GmbH & Co. KG with innovative state-of-the-art technology. This approach reflects our brand values: Reliable, Energetic & Brave.

18 to 44 tons total towing weight: Our heavy-duty e-trucks are used as electrically powered solo vehicles or as towing vehicles with trailers or as semitrailer tractors as well as tipper semitrailer tractors - highest efficiency, low noise level and no emissions.



QUANTRON

QHM

QUANTRON WE ARE YOUR SOLUTION QUANTRON.NET

Der QUANTRON QHM FCEV

The hydrogen-electric QUANTRON QHM sets standards for heavy long-distance transport: a range of up to 700 km/1,500 km thanks to a hydrogen tank capacity of up to 56 kg/116 kg, the integration of all components within the frame structure (without compromising on dimensions and application of the ISO directive for semitrailer combinations) and this with the special feature that long-distance cabins are also possible.

The hydrogen tanks are fully integrated in the chassis. In addition, H₂ consumption is optimized by a specially developed intelligent Q-ENERGY management system. This realizes maximum efficiency in the interaction between E-axle, fuel cell, high-voltage battery and 24V as well as HV auxiliary consumers.

Benefits Tractor-trailer retrofit

- FCmove™-XD 120 kW fuel cell from the world's leading hydrogen expert Ballard Power Systems
- Top range of up to 700 km (54 kg hydrogen tank capacity) or 1,500 km (116 kg up to 122 kg hydrogen tank capacity)
- Optionally available aero package, which improves the range by a further 10%
- Uncompromising integration of all components within the frame structure for maximum everyday usability (no „hydrogen backpack“ for standard configuration according to ISO 1726)
- Application of the ISO guideline for tractor-trailer combinations to ensure interchangeability of semitrailers and tractor units at national and international level
- Optimized H₂ consumption through intelligent Q-ENERGY management system
- Long-distance cabin
- government subsidies*



Technical data FCEV

Example configuration:

	FCEV 44-1000	FCEV 44-2000	FCEV 60-2000	FCEV 28-1000
Continuous Engine power	400 kW	400 kW	400 kW	400 kW
Max. engine power	550 kW	550 kW	550 kW	550 kW
Max. range	up to 700 km	up to 1500 km	up to 1100 km	up to 700 km
Tank volume	54 kg	116 kg	116 kg	54 kg
Battery capacity	118 kWh	118 kWh	118 kWh	118 kWh
Fuel cell power	240 kW	240 kW	240 kW	up to 240 kW
Axle configuration	4x2	6x2=2	6x2=2	4x2, 6x2-4
SOP	Q2 2023	Q3 2023	Q3 2023	Q2 2023



Axle configurations

FCEV

Tractors

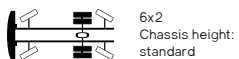
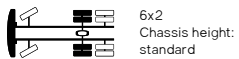
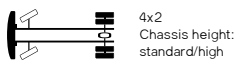

Chassis

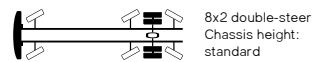
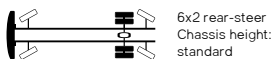
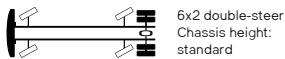
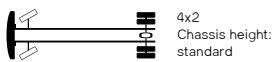

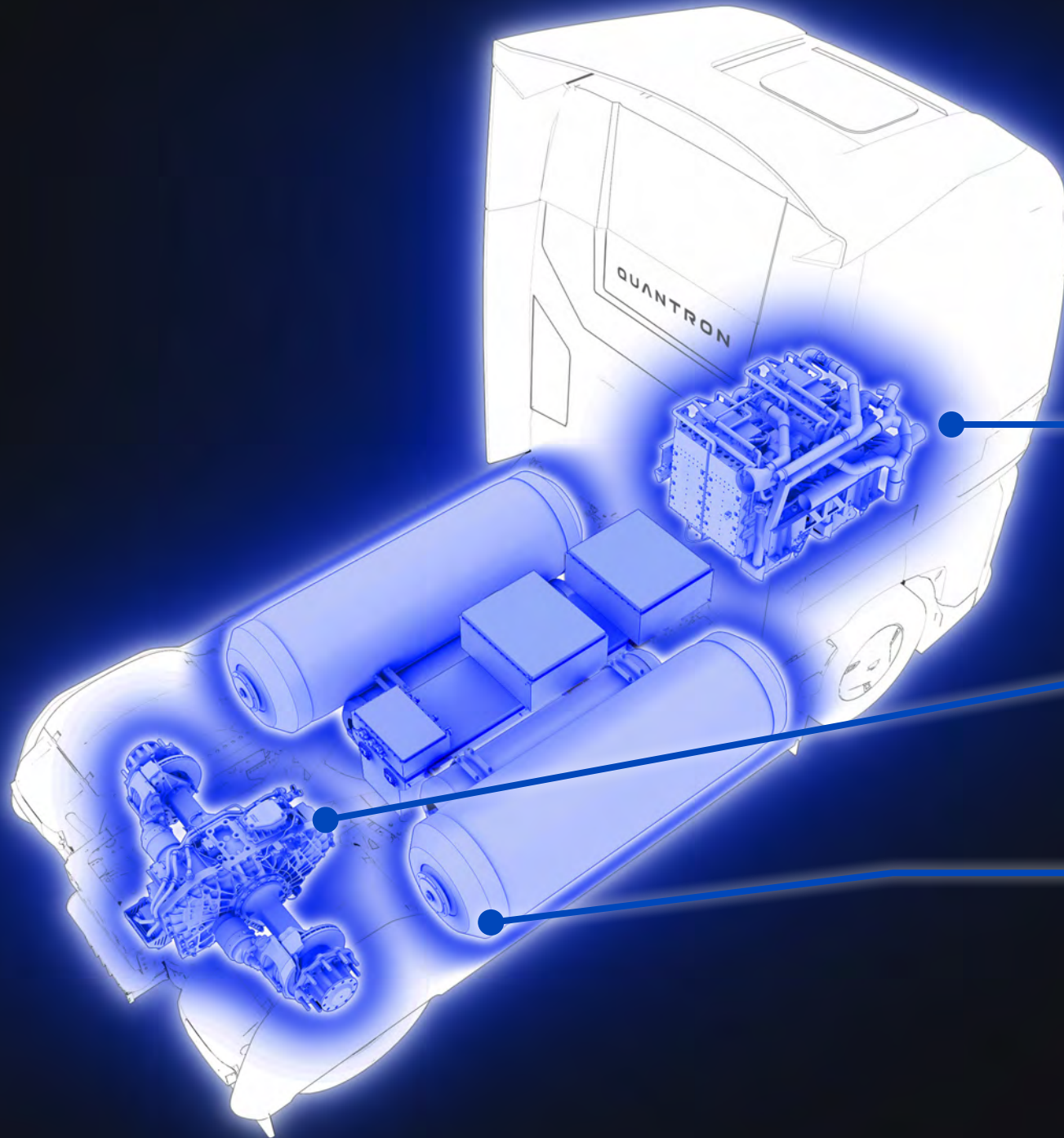

QUANTRON

QUANTRON INSIDE

FCEV truck platform

bundling world class components



Energy Management System for
Maximum Efficiency & Range

BALLARD™

- FCmove™-XD fuel cell with 240 kW (2x120 kW)
- 54 kilograms of on-board hydrogen storage
- 118 kilowatt-hour battery pack
- Range of up to 700 kilometers with 44 t total payload weight



- Allison eGen Power
- 130D with 450 kW continuous and 550 kW peak output Power

NPROXX

- Gravimetric storage density >7,1 %
- UN ECE 95 Crash Test ready
- H70HF ready industrialized globally-standard 70 MPa hydrogen heavy-duty vehicle high-flow





QUANTRON

QHM

The QUANTRON QHM BEV

The battery-electric QUANTRON QHM BEV is available as tractor unit QUANTRON QHM BEV 44-400 as well as chassis QUANTRON QHM BEV 27-400 in a variety of versions.

The high-voltage battery of up to 392 kWh can be charged with power of up to 350 kW DC and has a range of up to 350 km depending on weight and topographical requirements.

Unlike classic combustion engines, the BEV models are ideal for stop-and-go use and incur significantly lower maintenance and repair costs.

Benefits Tractor-trailer retrofit

- Close-to-production concept vehicle, available in a wide range of variants
- Up to 392 kWh large high-voltage battery
- Range of up to 350 km
- Electrification without changing the power take-off technology in “engine-dependent power take-off” or “transmission-dependent power take-off”
- Highest degree of standardization and ease of installation
- Ideal for stop-and-go applications
- Lower maintenance and repair costs than comparable diesel models
- government subsidies*



QUANTRON

Technical data BEV

Example configuration:

Tractor	BEV 44-400	BEV 27-400
Max. Engine power	375 kW	375 kW
Max. range	up to 350 km	up to 350 km
Battery capacity	280-392 kWh	280-392 kWh
Charging time	20-80 % SOC in less than 1h	20-80 % SOC in less than 1h
Max. Charging capacity	350 kW DC	350 kW DC
Min. wheelbase	3600 mm	3600 mm
Axle configuration	4x2, 6x2	4x2, 6x2



Axle configurations

BEV

Tractors

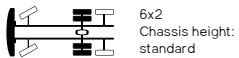
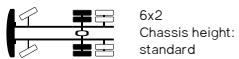
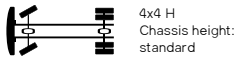
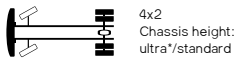

Chassis

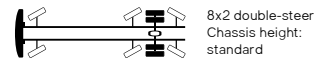
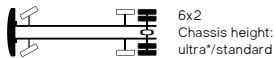
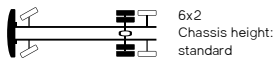
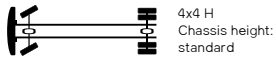
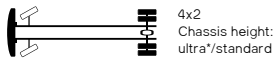

*Ultra variants on request





QUANTRON AERO KIT

„smart“ minor changes
lead to range improvements

- Ca. 20 % drag reduction
- Ca. 10% Range improvement
- With only minor changes
- QUANTRON & aeco.green Expertise
- Bespoke QUANTRON Design-Language for optimised Airflow and maximum efficiency

aeco.green

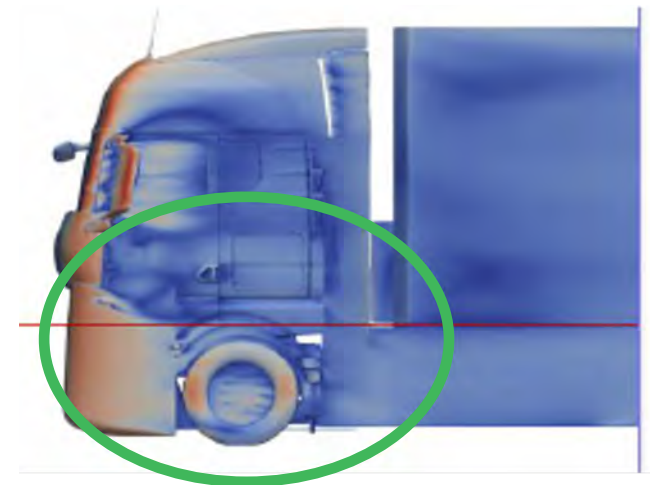
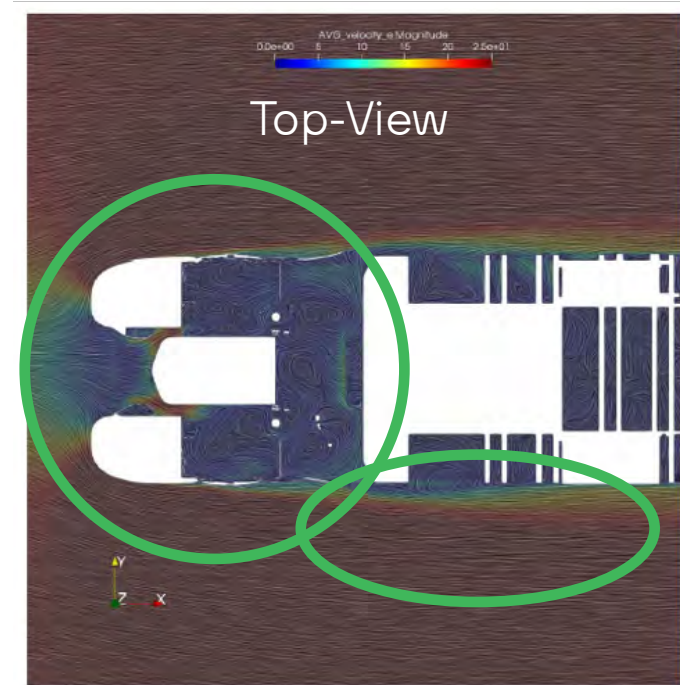



QUANTRON

QHB

QUANTRON WE ARE YOUR E-SOLUTION QUANTRON.NET

The QUANTRON QHB 27-200/280

Our heavy duty 6x2-4 e-chassis in configuration as a waste collection vehicle - highest efficiency and low noise level without emissions. The QHB 27-280 (based on the Mercedes-Benz Econic) has been on Germany's roads since mid-2020 and has been successfully tested in over 30 waste disposal companies.

For example, the waste collection vehicle was used in normal operation for more than two weeks in the waste disposal operation of the city of Ulm: around 900 waste garbage cans per day on an average route of 80 km. The actual range in 9-hour collection operation is well over 130 km without recharging the battery, and the range without taking into account the body energy requirement is up to 200 km with a battery capacity of 280 kWh.

The emission-free and quiet vehicle is not only a benefit for local residents. The elimination of exhaust gases and engine noise also significantly improves the working conditions of the chargers and drivers at the vehicle.

Benefits

- Payload with body mounted up to 11,000 kg
- Range up to 200 km depending on battery capacity without taking into account body energy requirements
- Direct drive, no transmission required
- e-PTO 50 kW output power for the body function
- Headroom in lowentry cab with high roof
- two wheelbases available, 3450/1350 mm and 3900/1350 mm
- three co-drivers possible in the cab
- Folding door on the passenger side for fast and trouble-free and trouble-free getting in and out of the cab
- High torque available already at start-up
- HV charger for 44 kW charging power installed on board
- CCS II charging port for 150 kW power can be ordered as an option

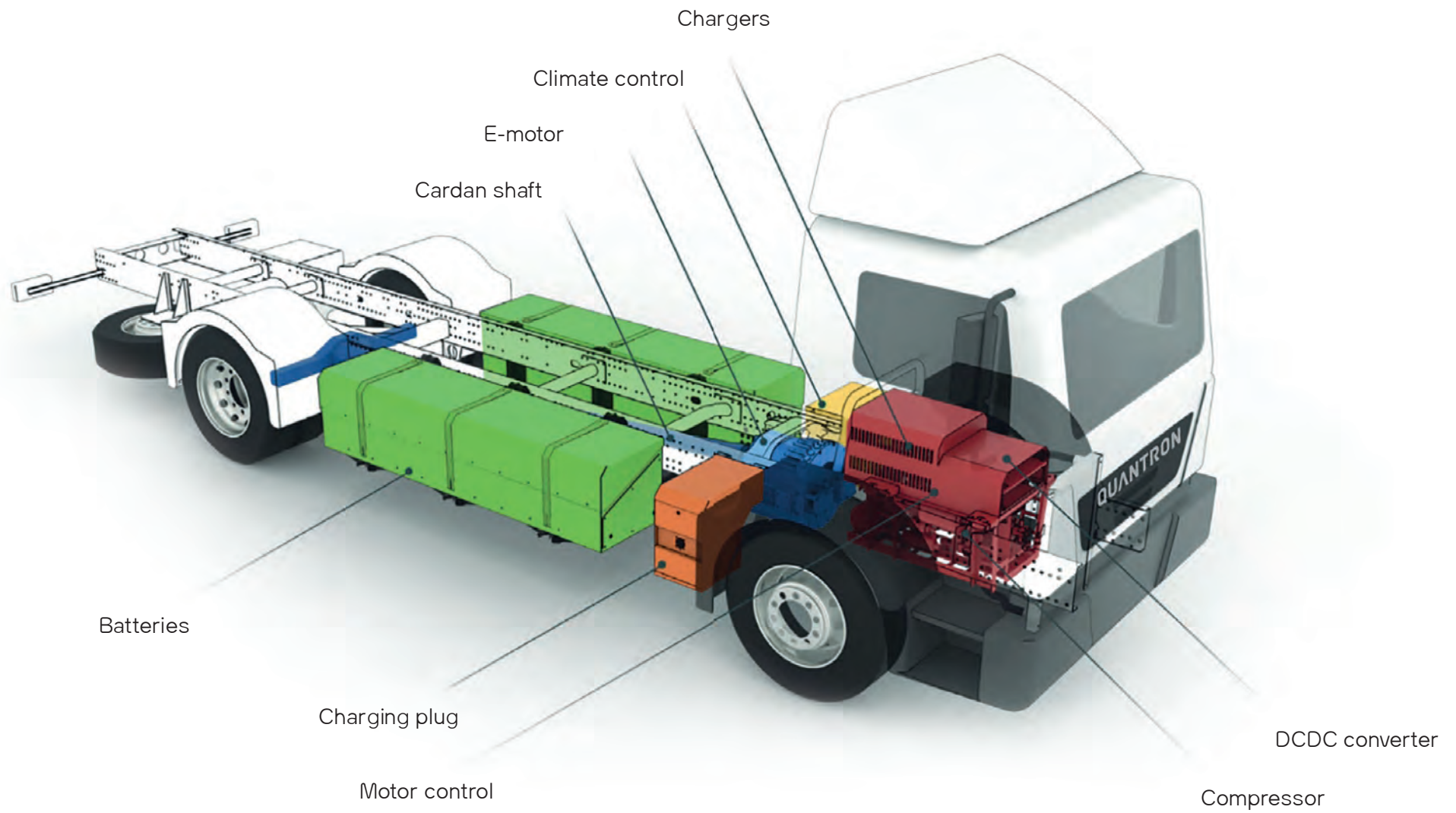

Technical data

Facts and advantages of the QUANTRON conversion based on the Econic

Max. motor power	350 kW
Range	up to 200 km
Battery capacity	200 kWh or 280 kWh
Charging time	4,6-6,4h (AC, 22/44 kW) or 1,5-2h (DC, 150 kW)
Gross vehicle weight	27.000 kg
Permissible axle load	FA 8t / DA 11,5t / LA 9t
Payload	11,080 kg or 9,938 kg
Tare weight cha. with body	15,920 or 17,062 kg
Wheelbase (min.-max.)	3,450/1,350 mm or 3,900/1,350 mm





Our way to a better future

QUANTRON Infrastructure

Regardless whether it is a charging station or wallbox, a conventional charging unit or fast charger, we support you with the necessary infrastructure according to your requirements. For easy handling, modern payment systems are integrated into our Q-Charging models.

New, stock or used

We focus on your requirements: Quantron AG supplies zero-emission new vehicles, electrifies your existing vehicles or converts used vehicles to environmentally-friendly electric drive versions for you.

Think Green – Second Life Vehicle

We give used commercial vehicles and buses a second, environmentally-friendly life - great potential for climate protection and resource management.

Second Life Battery

After 6-8 years, the used batteries enter their second life in the stationary area (e.g. in connection with photovoltaics as energy storage devices, for charging e-vehicles and absorbing peak currents).

The QUANTRON sustainability concept – Q-Retrofit

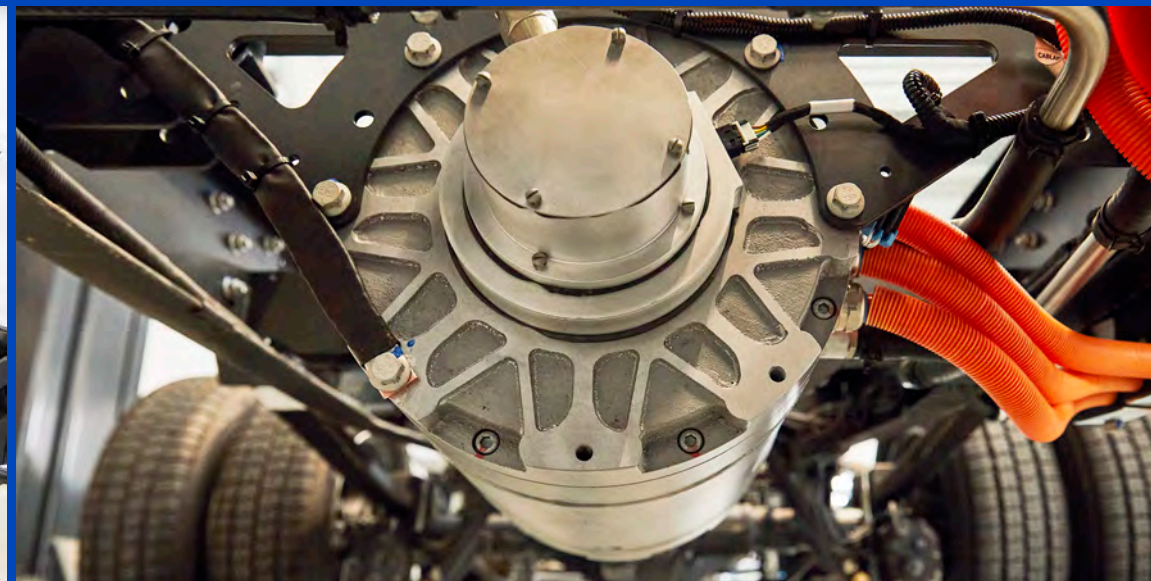
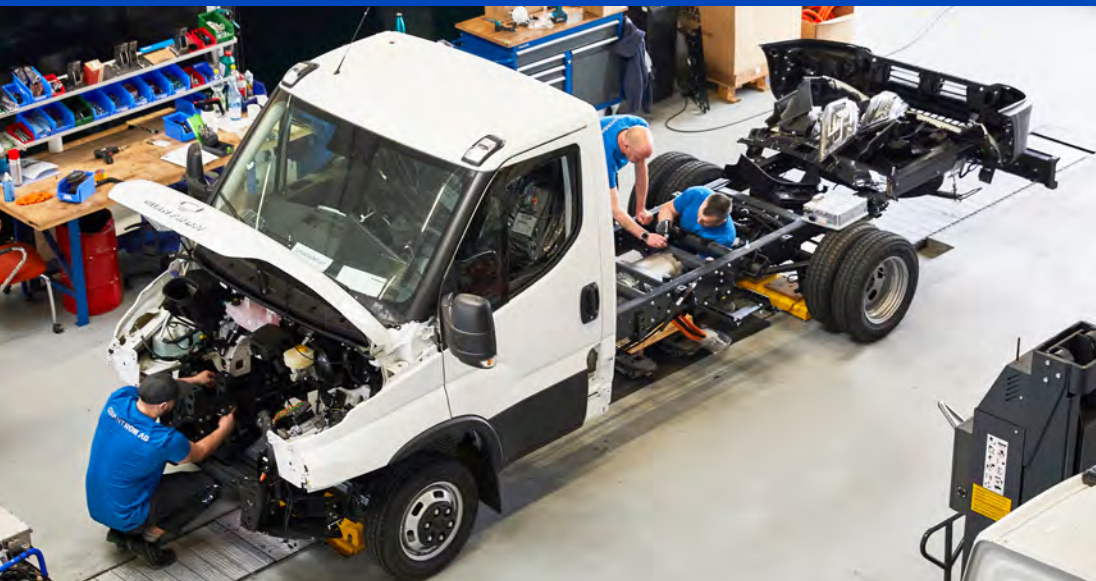
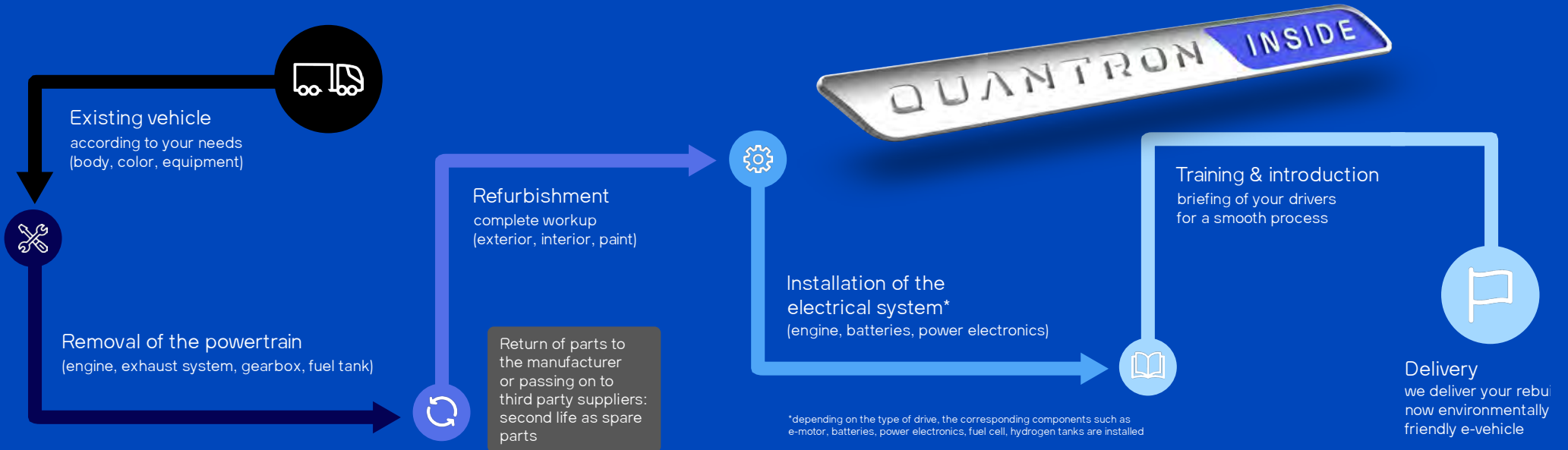

The QUANTRON CUSTOMER CARE Aftersales service circle

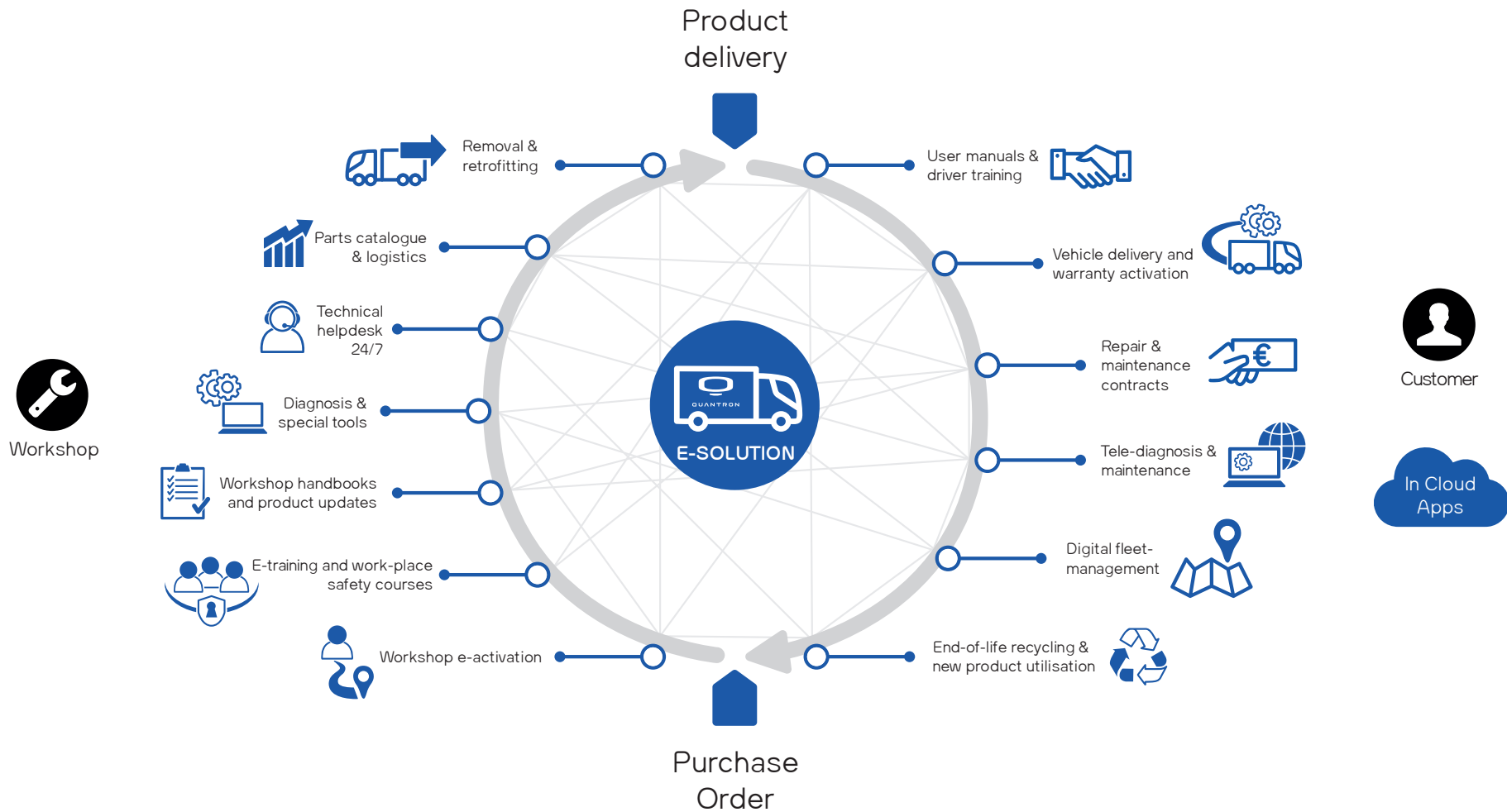

Combining product, organizational, digital and commercial know-how, QUANTRON-Aftersales offers a full package of e-mobility services to both, workshops and customers.



QUANTRON

QUANTRON
Lease Your Equipment

Finanzierung
Vermietung
www.hams

QUANTRON 360° Platform – Quantron-as-a-Service Zero Emission Solutions

QUANTRON ENERGY & POWER STATION

Production and distribution of green energy and hydrogen



H₂ refilling & electricity charging infrastructure network and equipment

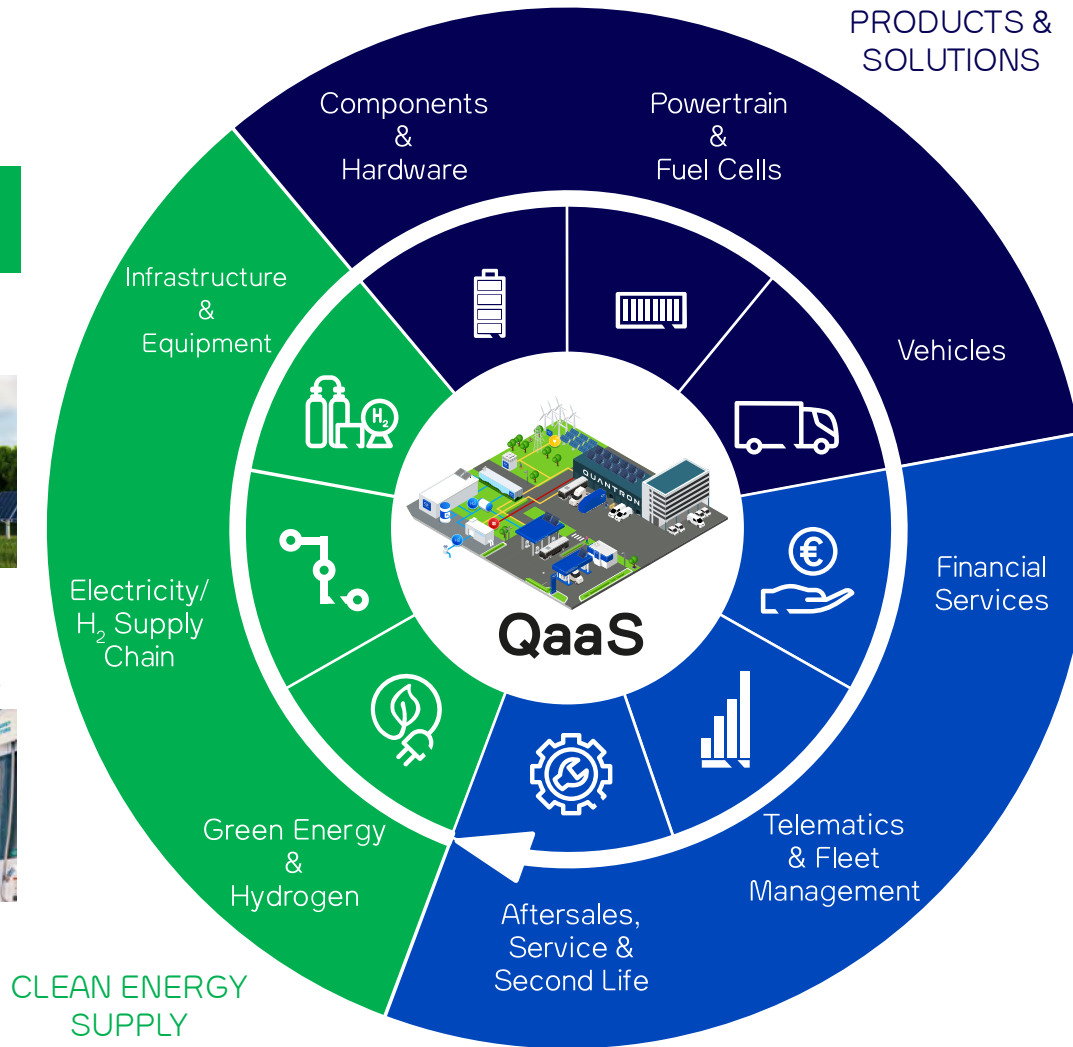

QUANTRON INSIDE

Fuel cell and battery electric commercial vehicles and components





QUANTRON CUSTOMER CARE

Physical and digital solutions for sales aftersales, financing and 2nd life

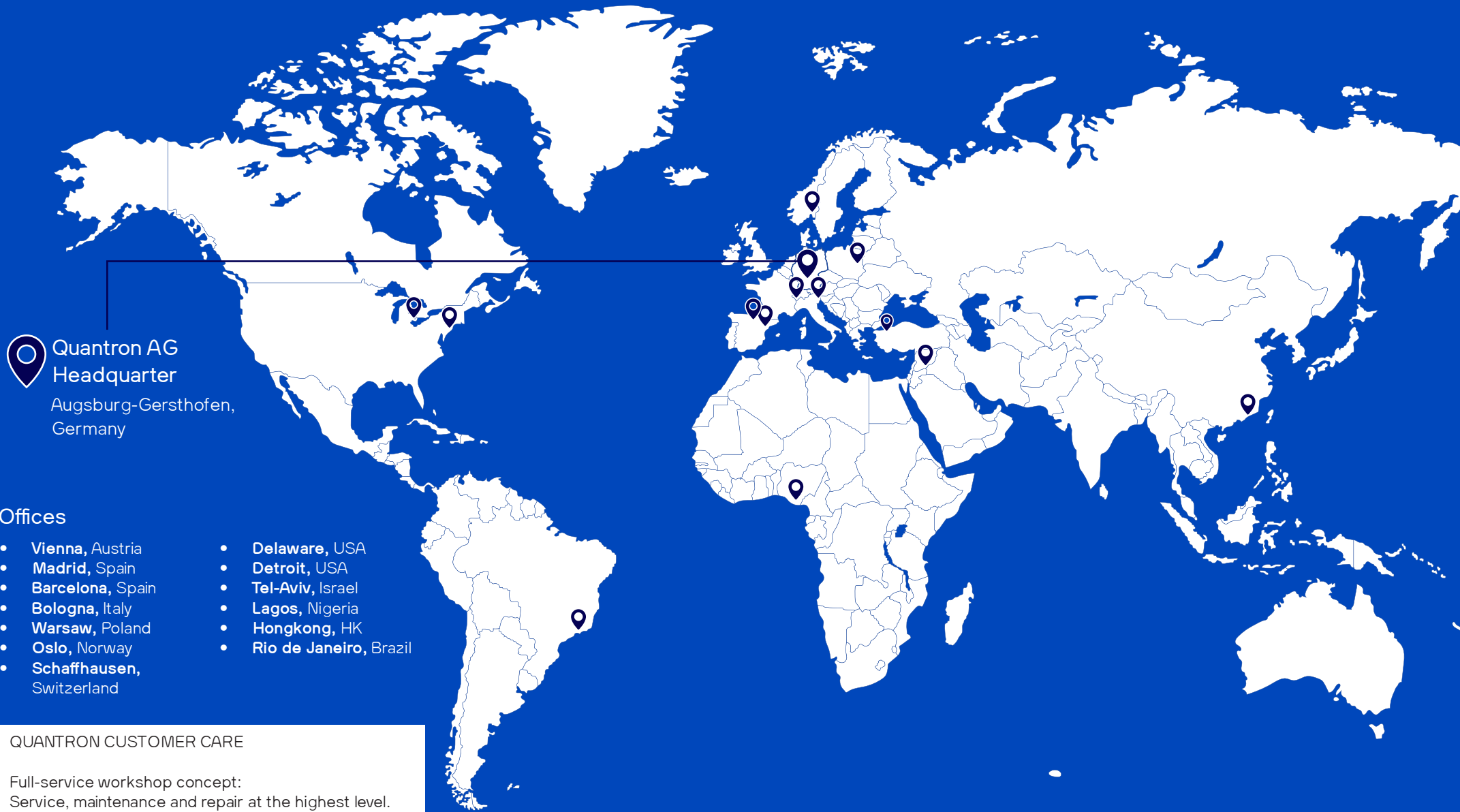

Global availability with a strong network of QUANTRON offices and 700 service partners



 **Quantron AG
Headquarter**
Augsburg-Gersthofen,
Germany

Offices

- **Vienna**, Austria
- **Madrid**, Spain
- **Barcelona**, Spain
- **Bologna**, Italy
- **Warsaw**, Poland
- **Oslo**, Norway
- **Schaffhausen**, Switzerland
- **Delaware**, USA
- **Detroit**, USA
- **Tel-Aviv**, Israel
- **Lagos**, Nigeria
- **Hongkong**, HK
- **Rio de Janeiro**, Brazil

QUANTRON CUSTOMER CARE

Full-service workshop concept:
Service, maintenance and repair at the highest level.
No matter if transporter, bus or truck. For all manufacturers.



Quantron AG
Koblenzer Straße 2
D-86368 Gersthofen/Augsburg
Phone: +49 (0) 821 78 98 40 - 0
Fax: +49 (0) 821 78 98 40 - 99
Mail: info@quantron.net
www.quantron.net

Status: 09/2022 | EN
QUANTRON reserves the right to change the technical characteristics
and specifications of its products without prior notice.